

## Chapter 6: State of the Art – History of Guarding

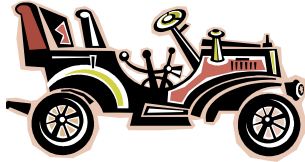

Sometimes, defendants raise the issue of state of the art. If it isn't invented, it is not state of the art. If it is available somewhere on the commercial market, it is state of the art. If the objective can be achieved with combinations of components and this information is known, it is state of the art. Interlocks on guards are ancient technology. No one can make a claim that guarding and interlocking guards is something new. It is not. Shown next is a 1913 patent: Read lines 12 through 21 of the written specifications of this patent.

A. H. BELL.  
SAFETY ATTACHMENT FOR STAMPING, PUNCHING, OR CUTTING MACHINES.  
APPLICATION FILED MAR. 5, 1912.  
1,082,188. Patented Dec. 23, 1913.

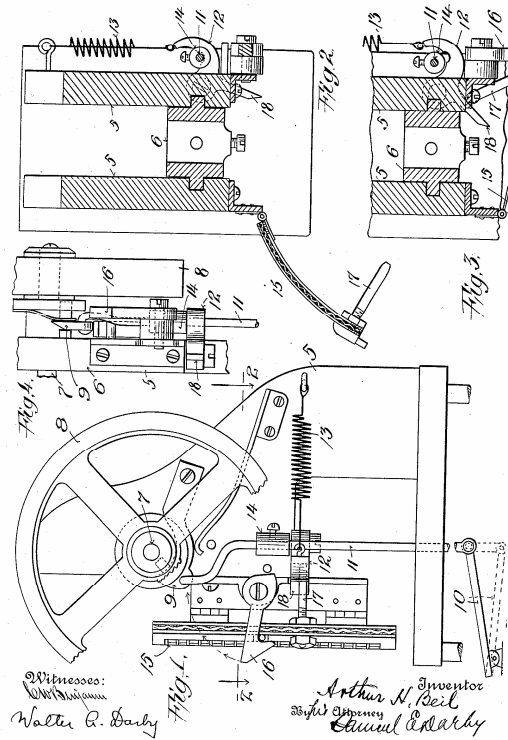

Figure 19: Early patent detailing safety features

# UNITED STATES PATENT OFFICE.

ARTHUR H. BELL, OF JAMAICA, NEW YORK, ASSIGNOR OF ONE-HALF TO FRANK D. CREAMER, OF BROOKLYN, NEW YORK.

SAFETY ATTACHMENT FOR STAMPING, PUNCHING, OR CUTTING MACHINES.

1,082,188.

Specification of Letters Patent.

Patented Dec. 23, 1913.

Application filed March 5, 1913. Serial No. 752,123.

*To all whom it may concern:*

Be it known that I, ARTHUR H. BELL, a citizen of the United States, residing at Jamaica, county of Queens, State of New York, have made a certain new and useful Invention in Safety Attachments for Stamping, Punching, or Cutting Machines, of which the following is a specification.

This invention relates to safety attachments for machines such as stamping, punching or cutting machines.

The object of the invention is to provide means in connection with a safety gate or barrier employed with machines of the character referred to whereby when the safety gate or barrier is opened, the operation of the machine in connection with which it is used is automatically arrested or the machine locked against operation and when the safety gate or barrier is closed, the machine is released ready for operation.

The invention consists substantially in the construction, combination, location and arrangement of parts all as will be more fully hereinafter set forth as shown in the accompanying drawing and finally pointed out in the appended claims.

Referring to the accompanying drawing and to the various views and reference signs appearing thereon:—Figure 1 is a view in side elevation, parts broken off and parts broken out showing the application of a safety attachment embodying my invention to a stamping or punching machine of typical design. Fig. 2 is a view in horizontal section on the line 2, 2, Fig. 1, looking in the direction of the arrows and showing the safety gate or barrier in open position and the lock mechanism in position to arrest or prevent the operation of the machine. Fig. 3 is a view similar to Fig. 2, parts broken off showing the arrangement of the locking mechanism in released position when the safety gate or barrier is closed. Fig. 4 is a broken view in front elevation showing an arrangement of clutch mechanism and the application thereto of a safety lock embodying my invention.

The same part is designated by the same reference numeral wherever it occurs throughout the several views.

In the operation of machines of various kinds, particularly stamping, punching and cutting machines, the danger is incurred of

injured through inadvertently placing the hand or finger in position to be caught by the reciprocating plunger or other moving part of the machine. It is customary to employ in connection with machines of the nature referred to a treadle mechanism through which the operation of the machine is controlled, a clutch device being operated by the treadle mechanism to throw the machine into and out of operation. In order to protect the hands of the machine attendant from accidental injury while operating the machine, it is a common expedient to employ a gate or barrier to prevent the attendant from gaining access to the working parts of the machine while it is in operation. Frequently, however, when the safety guard or gate has been opened by the machine attendant, in order to permit access to the working parts of the machine for adjustment of the work or for other purpose, through negligence, carelessness or other cause, the operation of the machine is not arrested or its operation is started up too soon or before the safety gate or barrier is closed with the frequent result of injuring or maiming the attendant.

It is among the special purposes of my present invention to provide means whereby when the safety gate or barrier is opened to permit access to the working parts of the machine, the machine becomes automatically locked against operation and remains locked against operation until the safety gate or barrier is again closed when the lock is automatically released by the act of closing the safety gate.

In carrying out my invention in its broadest scope, as defined in the claims, it is obvious that the particular type or design of machine to which the safety lock is to be applied is quite immaterial. It is also obvious that the manner of rendering the lock effective to arrest the operation of the machine is also immaterial.

As a practical and operative embodiment of my invention, I have shown a safety attachment or lock embodying the principles of my invention applied to a punching or stamping machine, the working part of which reciprocates vertically and the operation of which is controlled through a clutch mechanism which in turn is operated by means of a treadle to start and stop the machine and I have shown the safety lock

Figure 20: Early patent detailing safety features

This patent details an early form of interlocking. Interlocking can prevent many types of industrial machinery accidents. It is unfortunate that the technology to safeguard inherent machinery hazards has been available since at least 1913 and has not been implemented to its potential.